



2009 Burriss National Sprint and Speedway Series Introduction

Welcome to the Burriss National Sprint and Speedway Series! Both the BNSS and F200 programs are making big strides again compared to last season with programs expanding nationwide into both the sprint and oval markets. The F200 racing format is growing at an impressive rate in the Midwest (sprint & oval) and is steadily expanding to many sprint tracks up and down the West coast. Additional sprint F200 programs are in the works in Canada and a strong North East Asphalt oval circuit featuring the F200's is quickly becoming the premier asphalt oval series in that region. (The F200's superior power and higher quality engine components, versus the other "traditional" 4 cycle spec engines, has attracted interest from the 2 cycle crowd which has been a big help broadening its acceptance to all segments of karting.) Mini Sprints, Outlaw RWYB Karts, Jr Dragsters, as well as quarter and half midgets have all jumped on the F200 band wagon and it is becoming a legitimate engine structure in those forms of racing. With this wide acceptance, F200 is recognized as a "universal" format for many small engine racing groups and is a testament to the popularity of the concept and the recognition of the stable rules that govern it!

Take a look at our oval class structure and note that we still have classes for the 5 hp Briggs flat heads and we intend on keeping them in the program as long as there is sufficient participation to warrant this. We don't believe it would be fair or equitable to mix them with other engines (such as F200's or Animal's) so they will remain as stand alone classes as long as there is support. Our aim is to transition people leaving the flat head classes into F200 so that we can eventually reach our goal of an all F200 class structure within the BNSS. As participation gets to higher levels, we can then start modifying the class structure to one that is similar to Moto-Cross where the classes reflect a person's skill level or commitment, such as amateur, Masters, Pro, etc, and not what engine(s) or modifications they have. This way there are classes for the new drivers and/or Saturday night racers (Amateur) so they don't have to compete against the factory or sponsored (Pro) drivers, classes for our bigger and older Senior drivers or Super Heavy, and of course the F200 Pro classes to showcase our top drivers, engine builder and tuners. Also note that we have added specs for the "Clone" engine. These engines are available from many sources and are an inexpensive way to get people into our sport. These rules give our many BNSS tracks around the country the common structure they need for the Clone to compete seamlessly just like other engines of the BNSS.

Within karting only the F200 format can accomplish this because the engine rules are generic (like chassis rules); therefore the BNSS class structure won't be fragmented like the other sanctioning bodies do: with their Stock, Controlled Stock, TAG, one brand "Spec" engine

formats. This structure change is being readily accepted through out the industry and with the rapid growth of the BNSS and F200 this format looks like it will be a reality before long...

For those of you who are new to the BNSS and the F200 programs, take a minute and go to **www.speedway-karting.com**, click on the “**F200**” button at the top, and check out the “**Concept and Rules**”. This will give you an insight into this exciting new format that is really coming in to its own and is now having a big influence on karting’s future...

The growing interest in F200 from companies such as: Yamaha, Honda and Kohler, along with a large number of the automotive aftermarket businesses (K&N, Dyno Cams, Wiseco, Cometic Gaskets, etc) see this as an opportunity to participate in our sport from which they have been summarily excluded from in the past because other sanctioning bodies insistence on allowing only “approved”, “homologated”, and “spec” replacement parts.

The aftermarket companies have huge resources and will give BNSS participants the well deserved recognition and support, pledging to be a big part of our future growth! The simplicity and stability of the rules (with no meaningful changes in over 5 years!) have given these companies an incentive to participate, which will result in a “win/win” situation for everyone involved!

In addition to the F200 link, we have set up the “**No Spin Forum**” link which deals with all kinds of F200 and BNSS related topics from technical to race announcements, and is a valuable resource to shops, clubs, tracks, and individuals needing information about the BNSS/F200 scene. (Race schedules and special events can be viewed at **www.burrisnationalspeedwayseries.com**.)

Once again, the BNSS has made great strides in the last year, and with the help of the many dedicated and loyal supporters will continue to do so in the future.

Thank you and best of luck in the coming year!

Table of Contents

SECTION 1 -	PURPOSE AND INTENT	1
SECTION 2 -	GENERAL RULES AND GUIDELINES	2
SECTION 3 -	RACE PROCEDURES, GENERAL KART AND DRIVER SAFETY.....	4
SECTION 4 -	CHASSIS RULES	9
SECTION 5 -	POINTS AND AWARDS	17
SECTION 6 -	PROTEST PROCEDURE	18
SECTION 7 -	CLASS STRUCTURE	19
SECTION 8 -	GENERAL ENGINE RULES AND TECHNICAL PROCEDURES.....	21
SECTION 9 -	F200 TECHNICAL SPECIFICATIONS	24
SECTION 10 -	BRIGGS AND STRATTON 5HP TECHNICAL SPECIFICATIONS	27
SECTION 11 -	YAMAHA KT100 TECHNICAL SPECIFICATIONS	Error! Bookmark not defined.
SECTION 12 -	SECTION 12 - CLONE TECHNICAL SPECIFICATIONS	32

SECTION 1 - PURPOSE AND INTENT

- 1.1 The goals of the Burriss National Speedway Series are to promote karting at all levels and to create an atmosphere of competitive, safe and affordable racing for its participants and their families. These goals guide decisions made on and off the track. BNSS intends these rules to help local racing organizations and clubs create a safer environment for racing. Some local areas may have unique requirements so the rules and guidelines will require small modifications at the promoter's discretion. The primary goal of the rules and guidelines are to help protect the safety of the spectators, non-participants, race officials and drivers. The second goal is insure all participants are treated equally and fairly. The third goal is to promote sportsmanship for all participants. If you have any questions regarding the rules or procedures, please feel free to ask the local Race Director.

F200 and BNSS are registered trademarks of Burriss Racing. Any use or advertising of these rules or the BNSS and F200 trademarks with out the consent of Burriss Racing is strictly forbidden. To guarantee the integrity and global continuity of the BNSS and F200, any alteration to these rules or programs while running under the guise of F200 or BNSS formats is strictly forbidden.

SECTION 2 - GENERAL RULES AND GUIDELINES

2.1 Voluntary Association

- 2.1.1 Involvement with this racing series, the BNSS, is voluntary. If you register to race you are accepting the rules for the series. Please read and become familiar with them.
- 2.1.2 Although the rules are comprehensive, they may not address every situation. The Race Director of the event will consider the goals of the promoting organization, the BNSS, common sense and the spirit and intent of these rules to make a decision. The Race Director's decision is final.

2.2 Local option rules

- 2.2.1 Local promoting organizations may supplement the rules or guidelines. These supplemental rules should be documented, printed and distributed to the racers by the promoting organization.

2.3 Safety Policy

- 2.3.1 Kart racing is a risky pursuit. Safety is the first concern of the promoting organization and the competitors. Many of the rules and guidelines are for your safety and the safety of others. Please do your part in helping the promoting organization in making the track a safe racing experience for everyone.

2.4 Driver Age and Skill

- 2.4.1 The class structure details age or experience requirements for all class.
- 2.4.2 A driver's age on January 1st will determine their age for the calendar/competition year. On your birthday, you may choose to continue in the class you are racing until the end of the season or move up to the next age group.
- 2.4.3 A certified birth certificate or other locally defined documentation will be required as proof of age.
- 2.4.4 There may be a local option to allow experienced drivers to move to a different age class before reaching the minimum age of the class. Please check with the promoting organization about the policy at this track.
- 2.4.5 A driver must be able to demonstrate the required skills to enter a class, if requested to by the race director. If the skills do not meet the class standard of the participants to race in a class, you may be asked to race in slower or less crowded class for safety.

2.5 Competitor and Crew Conduct

- 2.5.1 All persons in the pit and paddock area shall conduct themselves in an orderly manner. No physical contact, verbal abuse or violence of any kind will be tolerated by an official, participant, spectator or other person. Violators of this policy will be asked to leave the facility and, if necessary, removed from the site. Local law enforcement will be called if needed.
- 2.5.2 Alcohol and drugs are not permitted in the pit and paddock area. Anyone using alcohol or drugs will be asked to leave and the participant will be disqualified from the event.
- 2.5.3 Competitors are responsible for the actions of their Crew. Unacceptable behavior may subject the driver to disqualification from an event. If a crewmember is asked to leave the facility for disorderly behavior, the competitor may also be disqualified at the discretion of the promoting organization. The race director's decision is final and cannot be protested.

2.6 Waiver of Liability and Minor's Releases

- 2.6.1 All persons entering the pit and paddock area are required to read, understand and sign the required document before entering. This is for your protection and the protection of the promoting organization.
 - 2.6.2 Failure to sign the required documents will be grounds for removal from the event.
 - 2.6.3 A Minor's Release is required for any person under 18 years old entering the pits. This requires a signature of the legal guardian and the minor. You are encouraged to review the waiver prior to coming to the track.
- 2.7 Fees and Charges
- 2.7.1 The promoting organization is responsible for posting fee schedules and payout schedules prior to the event.

SECTION 3 - RACE PROCEDURES, GENERAL KART AND DRIVER SAFETY

3.1 Registration

- 3.1.1 All drivers must register prior to the race.
- 3.1.2 If it's your first visit to this track, a responsible adult should accompany a junior driver to registration.

3.2 Pre Race Technical Inspection

3.2.1 Personal Safety Equipment

- 3.2.1.1 **Headgear:** Full-face helmets designed for competitive motorsports use, that comply with Snell Foundation specifications M95, SA95, K98, M2000, SA2000, SFI-31.2 or SFI-41.2 are mandatory. SA rated helmets recommended for Champ Karts. Helmet must be available at pre-tech inspection. Helmets must be secured with a strap. A full face shield, integral with the helmet, is mandatory.
- 3.2.1.2 **Neck Braces:** Collar-type, unaltered neck braces designed for motorsports use is mandatory in all classes. Loss of neck brace during the event will be cause for a black flag to be given to the driver losing the neck brace.
- 3.2.1.3 **Driver Apparel:** Driving suits are highly recommended in all divisions. (Drivers present a much more professional appearance when wearing a driving suit than they do wearing a jacket and "old" jeans and gives our sport a better public image.) Drivers can also wear jackets made of leather, vinyl, abrasion resistant nylon, or equivalent. Gloves, socks, shoes and long pants (if wearing a jacket) are mandatory.
- 3.2.1.4 **Flame-retardant suits** with an SFI-3.2A/1 minimum rating are recommended for Champ Kart drivers. SA rated helmets recommended for Champ Karts
- 3.2.1.5 **Arm Restraints** are mandatory and must be attached to restraint system in champ karts.
- 3.2.1.6 If driver's hair extends below the helmet the driver must wear a head sock or balaclava to prevent the driver's hair from extending below the helmet.
- 3.2.1.7 Loose clothing, bandanas, scarves, hoods, loose belts, etc. are not allowed.
- 3.2.1.8 The use of flak jackets or other chest protection devices is recommended.
- 3.2.1.9 All personal safety equipment is subject to, and shall be available for, pre-tech inspection.

3.2.2 Kart Requirements

- 3.2.2.1 The kart must be neat in appearance, in good repair, and show quality workmanship and must meet the requirements set forth in Section 4 of the BNSS Technical manual for its particular class.
- 3.2.2.2 Safety items and chassis/body work dimensions are subject to pre-race tech inspection only and are not part of the post race tech procedure. Any changes to pre-race tech items must be approved by the Race/Technical Director.

3.2.3 General Safety Equipment

- 3.2.3.1 Each kart team will have a working fire extinguisher. The extinguisher will be presented at pre-tech.
- 3.2.3.2 Kart teams are responsible for keeping their pit area free of litter and dangerous obstacles.
- 3.2.3.3 Flammable liquid will be stored the approved containers for that liquid and marked "Flammable".

3.3 Post Race Technical Inspection

- 3.3.1 Drivers must weigh after qualifying, each heat and the main event.
- 3.3.2 Carburetor venturi or restrictor plate diameters are subject to tech at any time.
- 3.3.3 The Technical Director will decide how many karts will be impounded for technical inspection. The Technical Director will decide what and how much tech will be done in each class. Tech may be waived if the top five drivers unanimously consent.

3.4 Driver's Meeting

- 3.4.1 All drivers will attend a mandatory driver's meeting. Local flag rules, grid, starting the race and yellow flag procedures, reentering the racetrack, lap traffic instructions and event schedule and safety issues will be discussed. The race director may elect to start any driver who misses the drivers meeting at the rear of heat and or feature event.
- 3.4.2 It is recommended that the crew chief / supervising adult accompany young racers to the drivers meeting.

3.5 Format

- 3.5.1 The promoting organization will select a format that is used for the events. The format will be based upon safety considerations, the time allotment, availability of equipment, scoring and officiating resources, and other local factors. Below are some options the promotion origination may select from.

3.6 Class Size Policy

- 3.6.1 Classes with 5 or more karts will race by themselves; classes with 3 or 4 karts should expect another class to run with them; classes with 3 or less will race with another class.
- 3.6.2 The popularity of some classes mandates there be a policy to control the number of karts in the Feature race. This policy applies to the classes posted by the promoting organization.
- 3.6.3 Motocross (Pea Pick) Format
 - 3.6.3.1 Each class will run 2 10-lap heat races and a 15-lap feature. The number of laps may be adjusted based upon the size on the facility. Check the local rules.
 - 3.6.3.2 Starting positions for the first heat races are based upon a draw. Positions are reversed for the second heat.
 - 3.6.3.3 Starting position for the feature will be based the driver with the best average finish in the heat races. Tie will broken by draw number
 - 3.6.3.4 The finishing order in the feature race will determine the final results.
- 3.6.4 Qualifying Format
 - 3.6.4.1 Each kart will run 1 or 2 qualifying laps. For tracks or events with electronic scoring, group qualifying may be used as a qualifying format. Best time will be posted as qualifying time. In case of a tie, the second fastest lap is the tiebreaker.
 - 3.6.4.2 The Feature line up will be based on qualifying times with the fastest kart on pole. In the event that there are more karts that attempt to qualify than there are available starting positions in the field the following is recommended. Lock in the top 75% of the field and fill the balance with second round qualifying or a "B" main. Events with large classes must post qualifying format for their events. (If a Pre-Final is run then the starting order for the Feature will be the finishing order for the Pre-Final)

3.6.4.3 The finishing order in the feature race determines the final results.

3.7 On Track Policy

3.7.1 Flags and their Meanings

3.7.1.1 Checkered Flag - the race is finished. Slow to a moderate pace for exiting the track. Proceed slowly to the scale and post tech area.

3.7.1.2 White Flag - one lap to go in the race.

3.7.1.3 Black Flag

3.7.1.3.1 Rolled & pointed: A warning about driver conduct

3.7.1.3.2 Waved (open) Black Flag: You must exit the track immediately because you have been disqualified for a driving infraction or unsportsmanlike conduct, unsafe equipment or loss of safety apparel. If a participant ignores the black flag along with his/her number being displayed by the flagman, that person will be disqualified for that race.

3.7.1.3.3 Meatball Flag (Black with a red ball): Will be thrown for technical or mechanical problems, requiring the driver to exit the track for consultation. This is an optional flag, the flagman may elect to use the black flag for mechanical problems. Driver may resume race after repairs.

3.7.1.4 Red Flag - the race has been temporarily halted. After slowing to a safe stop, drivers shall proceed safely to the starting grid under direction of the corner workers and flagman.

3.7.1.4.1 If the red flag occurs prior to the halfway point, the race may be restarted. Restarts will be in the same order as the last completed and scored green flag lap prior to the red flag.

3.7.1.4.2 If the red flag occurs at or after the halfway point, the race may score as a completed race and the results will reflect the last completed green flag lap. Karts involved in the incident will be scored at the rear of the field. The officials will make every effort for the event to finish under a green flag, however time and local conditions may require the race to be scored as complete. Red flagged races will be declared official if the track officials decide the event cannot be completed. The race director will decide if your kart can restart the event

3.7.1.4.3 Any kart or driver flipping over (turning over) causing a red flag will only be allowed to restart with the permission of the race director and the Emergency Medical Personnel's approval. Any driver leaving the racetrack, due to an accident, by ambulance, will not be allowed to restart. Any driver causing a red flag may be subject to not restarting, as determined by the race director.

3.7.1.4.4 Any kart involved in an accident whose driver is transported to a health care facility is subject to post tech. If driver does not return from the health care facility prior to the end of post tech, scales will be waived. The kart must be safety inspected before reentering the track

3.7.1.5 Green Flag - Start; course is clear.

3.7.1.6 Blue Flag with Orange Stripe or an all Blue Flag - A lapping kart is attempting to pass, give him consideration. If you continue to block the progress of the faster karts, you may be black flagged and pulled off the course.

3.7.1.7 Yellow Flag - there is danger on the course and there is a need for caution.

3.7.1.7.1 When a yellow flag is displayed anywhere on the track, it signifies a full course caution. Do not race back to the line on a yellow flag. When the

- yellow flag is displayed, slow down. There will be no passing until the green flag is displayed again. The leader will raise their hand so the field can reform in single file for the restart.
- 3.7.1.7.2 All of the participants involved in the incident will start at the back of the field on the restart. If you are involved in the incident do not expect to "get your spot back". Note, this rule doesn't state who caused the yellow, it's says, "all karts involved" including karts that spun to avoid the incident.
 - 3.7.1.7.3 Yellow flag laps and pace laps are to be run at a reduced pace (speed) by the race leader. The field should look for safety personal on the track. Watch the officials for signals as to where you restart.
 - 3.7.1.7.4 Position will be based on the last completed and scored green flag lap. If you don't know where to restart pull out of line and raise your hand so the flagman and official can get you in the correct spot. No passing will be allowed when yellow flag is displayed.
- 3.7.1.8 The yellow flag is used to protect the drivers on the track. If there is not a danger to a kart or driver, the yellow will not be thrown.
 - 3.7.1.9 NOTE: Flags can vary from track to track. If there is a variation from the above it will be brought up at the drivers meeting
 - 3.7.1.10 Racing is not a contact sport. Although it is understood some inadvertent contact will occur, intentional and avoidable bumping, nerfing, pushing, etc., will be grounds for disqualification. You will be warned only once with a rolled black flag, a second warning will result in a waved black flag.
 - 3.7.1.11 The pit lane will be a yellow flag condition and a safe speed will be maintained. No passing will be allowed while entering the pit lane. Passing and/or unsafe driving in the pit lane will result in disqualification.
- 3.7.2 General Rules
- 3.7.2.1 The Race Director may disqualify a competitor for the race, event or season depending on the seriousness of the infraction.
 - 3.7.2.2 Data acquisition is legal in all classes. The retrieval of the following functions only is legal: RPM and speed, lap timing and computer scoring systems, water, cylinder head and exhaust temperatures, and G sensors.
 - 3.7.2.3 Radio communication between driver and pit is illegal in all classes.
 - 3.7.2.4 Approved exhaust silencers or mufflers are recommended in all classes. See Section 8 for the rules for approved silencers.
 - 3.7.2.5 The use of tire warmers and open flames on the grid or pre-grid is illegal. Open flames are also illegal in the pit area.
 - 3.7.2.6 Karts should be on the grid when their class is called and the grid closed in an appropriate amount of time prior to that class's start. This will allow tires to stabilize to ambient temperature and a random check with a heat gun to verify that tire warming didn't take place. It is recommended that a mounted tire be placed in the sun as a reference for the heat gun. Karts not reporting to the grid on time will go to the back of the grid.
 - 3.7.2.7 When the grid is opened for karts to enter the track and line up it will be open for 90 seconds. After 90 seconds (or the green flag is displayed) the grid area will then be closed until the race is completed.
 - 3.7.2.8 There will be no working on karts on the race track or infield unless there is a Red flag and the Race Director allows it. Any karts that need repairs or to be

restarted need to do it in the grid area and if time allows they can return to the track but must start in the back.

3.7.2.9 Team driving is not allowed. Karts deemed to be driving, as a team or “pushing” will be Black-flagged. If the kart in front feels he is being illegally pushed he should raise his hand the wave off the offending driver when passing the starter stand.

3.7.2.10 The promoting organization, may at its own discretion, impose a gear ratio limit to keep speeds and/or rpm’s to a reasonable level for prevailing track conditions.

3.7.3 Safe Driving

3.7.3.1 Competition is expected to proceed with out you endangering yourself or others. If in the judgement of the race official, a driver bumps, crowds, or pushes another driver, the offending driver may be disqualified.

SECTION 4 - CHASSIS RULES

Speedway (Oval/Offset) Chassis Specifications (Sprint and Champ)

4.1 Tires

- 4.1.1 Asphalt Oval: Burriss B44A or B55A's only. (SS series also legal)
- 4.1.2 Dirt Oval: Any Burriss "B" series tire in all sprint type chassis classes. B44A and B55A's only in Champ classes. (SS series legal in both divisions)
- 4.1.3 The use of "prep" or other chemicals of any type inside or outside the tire is not allowed. Tires can be cleaned with water and Simple Green if desired.

4.2 Wheels must be 5" or 6" bead diameter with an O/A 10 3/8" maximum width. Aluminum only.

4.3 Main frame members shall be constructed of cold rolled, electric weld, round, steel tubing or other material of equal or greater strength, of one inch minimum nominal outside diameter and .078 inch minimum wall thickness and 1.400 inch maximum nominal diameter. Tubing of 1.125 inch nominal and greater may have a wall thickness of .060-inch minimum. Main frame rail members shall be no higher than a horizontal line extending from the centerline of the front wheel to the centerline of the rear wheel. No oval tubing allowed.

- 4.3.1 Rear axles to be constructed of ferrous metal or aluminum (No titanium). 1 3/8" maximum diameter. Both drive wheels must be secured to the axle and cannot rotate independent of each other.

- 4.3.2 The use of any type of suspension components is strictly prohibited.

- 4.3.3 Brakes: Hydraulic disc types that brake the rear wheels only. No front wheel brakes. Steel or iron rotors only. For all F200, KT100 and Unlimited classes the minimum rotor (disk) diameter and width is 7.1" x .18". All bolts and fasteners to be safety wired or cotter keyed.

- 4.3.4 Brake rotor cover: A flat metal disc cover ("Wolf plate") between the seat and brake rotor is mandatory.

4.3.5 Steering:

- 4.3.5.1 Solid steering shafts shall be a minimum .625" diameter, made of cold rolled steel, and one-piece design. Welding the steering wheel or hub to the shaft is not allowed. Shaft extensions, and cutting and welding the shaft to alter its length is not allowed. The steering wheel must be secured to the shaft with a nut or cap screw in the axial position. Quick release type steering wheel mandatory on all Champs and is optional on sprint chassis. Hollow shafts shall be a minimum of .700" diameter X .070 minimum wall steel tubing. Steering hub must be mounted by a 1/4" bolt parallel to its axis point. Tiller type shaft steering systems are not allowed.

- 4.3.5.2 All steering component bolts, and nuts, must be cotter keyed and/or safety wired and must be a minimum grade 5 rating.

- 4.3.5.3 Steering wheels may be circular, with a ten-inch minimum diameter, and a minimum of three spokes or the butterfly type, with a ten-inch minimum diameter, and four spokes, and a minimum grip length of five inches on each side.

- 4.3.6 Fasteners used on any component that will enable adjustment of camber, caster, etc. must be cotter keyed and/or safety wired.

- 4.3.7 All weights added to the kart must be securely fastened to the kart with a minimum 5/16-inch diameter bolt. Any single weight weighing in excess of seven pounds must utilize a minimum of two 5/16-inch minimum diameter bolts. All

bolts used to fasten weights to the kart must be cotter keyed, safety wired, or double nutted.

4.3.7.1 All weights attached to karts must be painted white. It is also recommended that your kart number be on the weight.

4.3.8 Rear view mirrors are prohibited.

4.4 Speedway Sprint Chassis specifications

4.4.1 Wheelbase: 43.0 inches maximum, 40.0 inches minimum. Wheelbase is measured from true axle centerlines, each side.

4.4.2 Track width: 28.0 inches minimum. Track width may be measured from the outside edge of one tire to the inside edge of the opposite tire when both tires are of identical width.

4.4.3 Overall width: 50.0 inches maximum for all classes. Overall width is measured at any cross section of the kart, perpendicular to the longitudinal centerline axis.

4.4.4 Overall length: 74.0 inches maximum. Overall length is measured at any cross section of the kart, parallel to the longitudinal centerline axis.

4.4.5 Overall height: 26.0 inches maximum. Overall height is measured such that all elements of the kart must pass under a bar set parallel to ground level, 26.0 inches above ground level.

4.4.6 Dry kart weight: 85 pounds minimum in race ready trim without fuel.

4.4.7 Front bumper: All components shall be constructed of round, .065 wall steel tubing of .750-inch nominal diameter minimum. The uppermost tangent point of the top hoop shall be 7.75 inches minimum from ground level.

4.4.8 Rear bumper: All components shall be constructed of round, .065 wall steel tubing of .750-inch nominal diameter minimum. The uppermost point of the top hoop shall be 7.5 inches maximum from ground level and no lower than the bottom of the rear axle. Minimum width shall be no less than the lateral distance between the main chassis frame rails as measured at the rear of the kart. Maximum width shall be no wider than the rear overall width of tires.

4.4.9 Nerf bars: All components shall be constructed round, .065 wall steel tubing of .750-inch nominal diameter minimum. The rear portion shall not extend laterally beyond the rear tire and must be a minimum of 24" long.

4.4.10 Seat: Must be of conventional, unaltered, bucket type, molded construction, designed to keep the driver's posterior in place without undue movement. The seat shall be mounted between the main frame rails. The rearmost point on the seat may not extend beyond the back of the rear axle. Headrests are not permitted (except in Champ Karts). Steering uprights shall be positioned in such a manner as to prevent the driver's posterior from being positioned forward of the bucket portion of the seat.

4.4.10.1 Height of the uppermost point of the seat backrest is 10.0 inches minimum from ground level for Jr. I and Jr. II classes

4.4.10.2 Height of the uppermost point of the seat backrest is 12.0 inches minimum from ground level for Jr. III classes

4.4.10.3 Height of the uppermost point of the seat backrest is 14.0 inches minimum for senior classes.

4.5 Speedway Racing Bodywork Requirements

4.5.1 All bodywork components must be constructed of high strength plastic, fiberglass, or advanced composites. No metallic materials to be used for side panels or nose cones.

- 4.5.2 No component of the bodywork may be adjusted or controlled in any way while the kart is in motion.
- 4.5.3 Skirting devices must be constructed of a flexible, non-metallic material.
- 4.5.4 The sides of the tires may not be covered in any way by the nose cone or side panels. It must be possible to remove the wheel straight through the opening in the bodywork.
- 4.5.5 Nose cones: The nose cone may cover the driver's foot area, but not to extend further than 3.0 inches rear of the pedals in relaxed position. This measurement shall be made directly over each of the two pedals. The bottom of nose cone may extend full width no farther than the rear of the front tires, in a straight-ahead position, beyond that the bottom of the nose cone must be within the main frame rails. The nose cone may be no narrower than to expose one half of a tire width per side. Maximum nose cone height 14.0 inches for Jr I & Jr II classes only.
- 4.5.6 A connecting strip from nose cone or floor to steering fairing is allowed up to 6.0 inches maximum chord width, so as not to cover the driver's feet, or legs. Minimum six-inch clearance from connecting strip or steering fairing to any other bodywork component begins three inches maximum aft of the pedals, extending rearward to the mounting point for the steering wheel.
- 4.5.7 Steering fairings: Chord length 14.0 inches maximum. Chord width 14.0 inches maximum. Clearance to steering wheel 3.0 inches minimum. Clearance to any other bodywork or fuel tank 6.0 inches minimum. Clearance from steering wheel to any other bodywork 6.0 inches minimum. No steering fairings in Jr. Sportsman Classes.
- 4.5.8 Belly pans: Full width belly pans within the main frame rails are allowed for all classes. Belly pans can be bent up to a point no higher than the centerline of the rear axle.
- 4.5.9 Height from ground level of all side panels and rear pods: 16.0 inches maximum.
- 4.5.10 No bodywork component may extend past the rear tire.

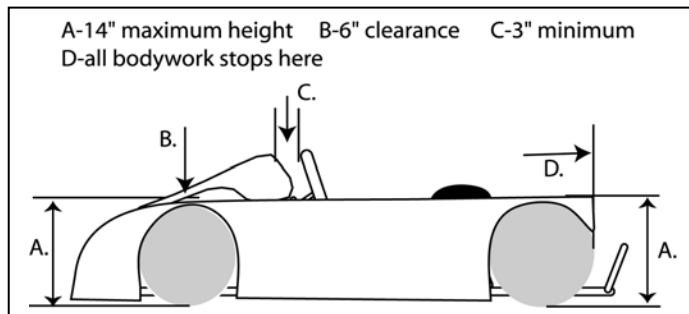
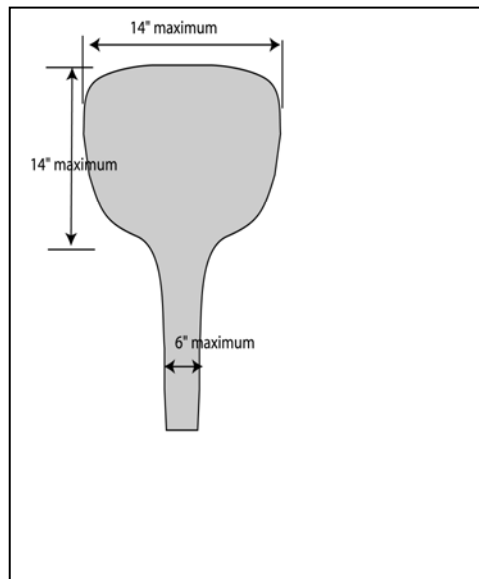
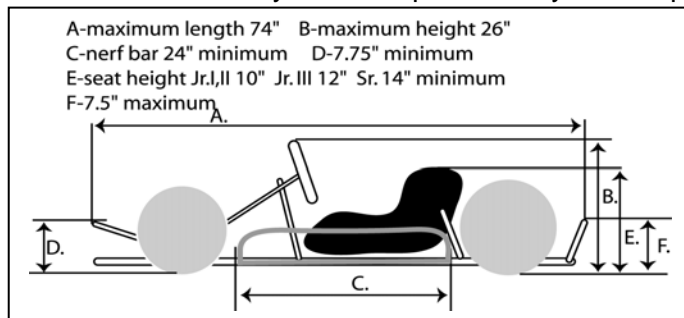

4.6 Senior/Junior Champ Kart Chassis

- 4.6.1 Main frame members shall be constructed of cold rolled, electric weld, round steel tubing or other material of equal or greater strength, of 1.125-inch nominal minimum diameter, .083 inch wall thickness. Conventional tubular space frame construction methods only are allowed. (No bolt on cages) Pre 2002 model Champ Karts accepted providing they are in their original manufactured configuration. No modifications to the chassis or cage allowed. Legality of non-conforming karts to be determined by the Race Director.
- 4.6.2 Wheelbase: 42.0 inches minimum, 45.0 inches maximum. Wheelbase is measured on true axle centerline, each side.
- 4.6.3 Overall width: 40.0 inches minimum, 52.0 inches maximum. Overall width is measured at any cross section of the kart, perpendicular to the longitudinal centerline axis.
- 4.6.4 Overall length: 95.0 inches maximum. Overall length is measured at any cross section of the kart, parallel to the longitudinal centerline.
- 4.6.5 Roll cage specific specifications
 - 4.6.5.1 Full roll cage of four point conventional construction is mandatory. The four uprights and top horizontal connecting tubes must be constructed of 1.125-inch nominal minimum diameter mild steel tubing. All attachments by welding unless otherwise specified.
 - 4.6.5.2 Uprights and positioning: Each of the rear uprights must be welded to the main frame rails at a point aft of the rear axle centerline. Each of the front uprights must be welded to the side frame rails at a point forward of the steering wheel mount point and aft of the leading edge of the front tire. All uprights must create an angle of no less than 45 degrees with the main frame rails and have no bends within three inches of attachment point except for left rear.
 - 4.6.5.3 Top hoop rails: Corner construction shall be of rounded type with no sharp edges or corners allowed.
 - 4.6.5.4 Shoulder harness mounting bar shall be welded laterally between rear uprights, double braced to the top lateral bar, at a height suitable for harness mounting. A minimum 6.0-inch square headrest shall be mounted to the braces level with the driver's head.
 - 4.6.5.5 Side protection bars are mandatory and must run horizontally between front and rear uprights each side. One end connection may be slip jointed. Side protection bars must be positioned vertically between the driver's shoulder and elbow.
 - 4.6.5.6 Roll cage side bar C overall width: 16.0 inches minimum 24.0" maximum. Width to be measured outside to outside between any two uprights.
 - 4.6.5.7 Roll cage overall height: 38.0 inches minimum. Height to be measured vertically from highest lateral cross bar centerline to main frame rail centerline.
 - 4.6.5.8 All roll cages that deviate in any way from the above description must be brought into conformity or receive approval from the race director or tech inspector prior to be used in competition.
- 4.6.6 Front bumper: All components shall be constructed of round, .065 wall steel tubing of .750 inch nominal diameter minimum. Front bumper must encircle entire front nose area at a height of 7.75 inches minimum from ground level. Double bumpers are recommended.

- 4.6.7 Rear bumper: All components shall be constructed of round, .065 wall steel tubing of .750 inch nominal diameter minimum. Double bar construction is mandatory. Rear bumper must encircle the tail section of the kart. The top of at least one bar must be 7.50 inches maximum from ground level.
 - 4.6.8 Nerf bars: All components shall be constructed of round .065 wall steel tubing of .750 inch nominal diameter minimum. Double bar construction is mandatory. The top of the upper bar must be no higher than the top of the rear tire. The bottom of the lower bar must be no lower than the bottom of the main frame rails. Nerf bar must extend from an area inside a longitudinal line from the outer portion of the front tire to a point no further outboard than 1.0 inch from outer tire surfaces.
 - 4.6.9 Seat positioning: No part of the seat may be positioned closer than six inches inside the left-hand nerf bar.
 - 4.6.10 Harness: five points, SFI-rated racing harness is mandatory. Metal to metal harness fastener is mandatory. Mounting bolts must be cotter-keyed and attach to a 3/16 inch minimum thick, 2.0 inch minimum square steel mounting plate that is welded to the frame and/or roll cage. Arm restraints, attached to the harness, are mandatory.
- 4.7 Champ Kart Bodywork Requirements
- 4.7.1 All bodywork components must be constructed of high strength plastic, fiberglass or advanced composites only.
 - 4.7.2 No component of the bodywork may be adjustable in any way while kart is in motion.
 - 4.7.3 Bodywork must be confined to the area defined by the front and rear bumpers, inside the area defined by the inside sidewalls of the tires.
 - 4.7.4 Cockpit must be entirely open when viewed from above.
 - 4.7.5 Wings, spoilers or other aerodynamic effects are prohibited. Including wind deflectors attached to the roll cage
 - 4.7.6 Full, midget/sprint type, open wheel, conventional construction methods only is approved. Flat panels are allowed only for side panels and all other body components must have rounded, compound curve configuration. Nose bodywork is mandatory.
 - 4.7.7 Full enclosing Midget/Sprint type tail section recommended. 15.0 inches minimum length, 13.0 inches minimum width and 14.0 inches minimum height.

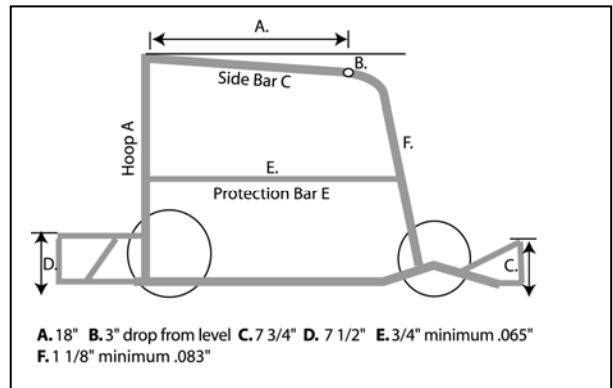
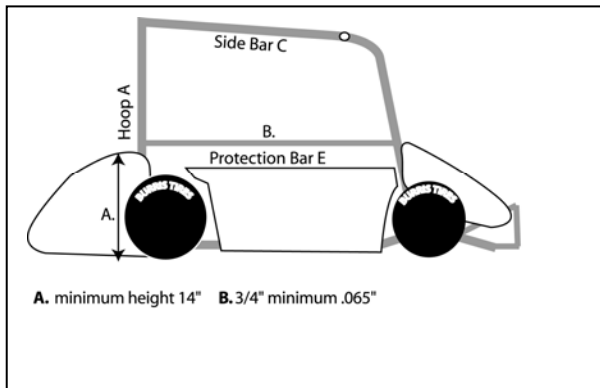

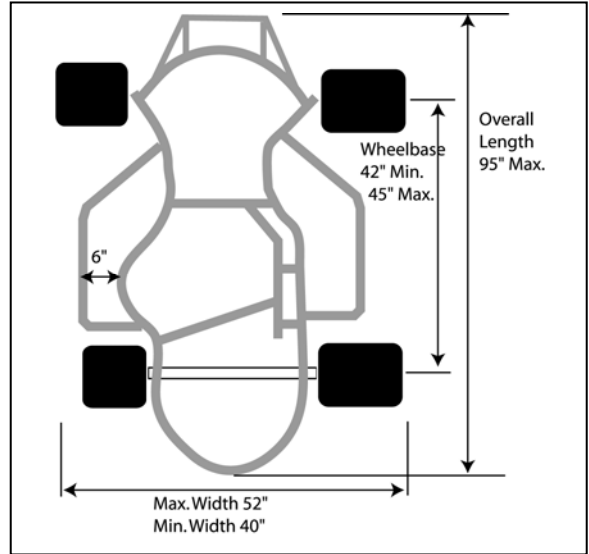
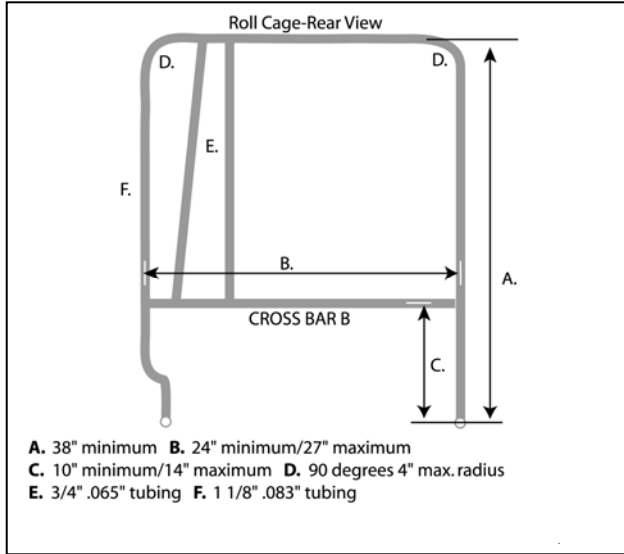

4.8 Junior Sportsman Champ Kart Chassis Specifications

- 4.8.1 Mainframe members shall be constructed of cold rolled, electric weld, round steel tubing or other material of equal or greater strength, of 1.125 inch nominal minimum diameter, .083 inch wall thickness. Conventional tubular space frame construction methods only are allowed. (No bolt on cages) Pre 2002 model Champ Karts accepted providing they are in their original manufactured configuration. No modifications to the chassis or cage allowed. Legality of non-conforming karts to be determined by the Race Director.
- 4.8.2 Wheelbase: 40.0 inches minimum, 43.0 inches maximum. Wheelbase is measured on true axle centerline, each side.
- 4.8.3 Overall width: 38.0 inches minimum, 50.0 inches maximum. Overall width shall be measured from outside tire sidewall to opposite outside tire sidewall.
- 4.8.4 Overall length: 81.0 inches maximum. Overall length is measured at any cross section of the kart, parallel to the longitudinal centerline.

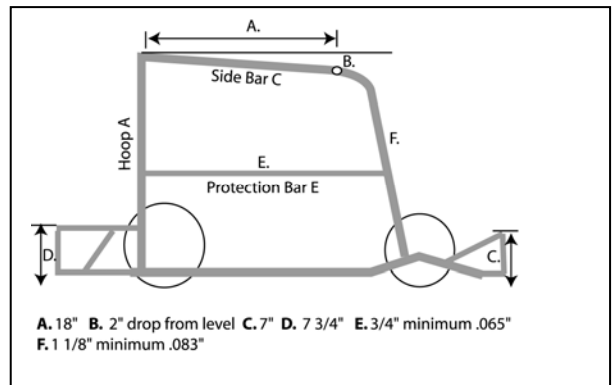
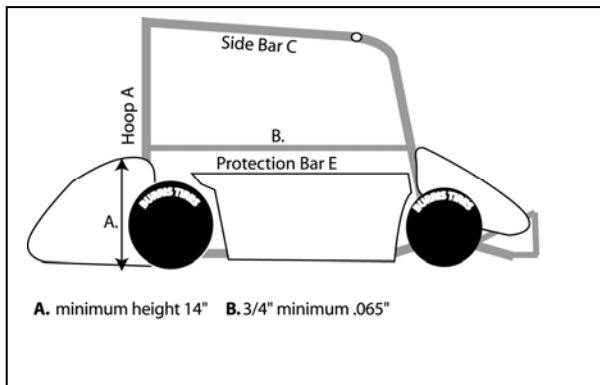

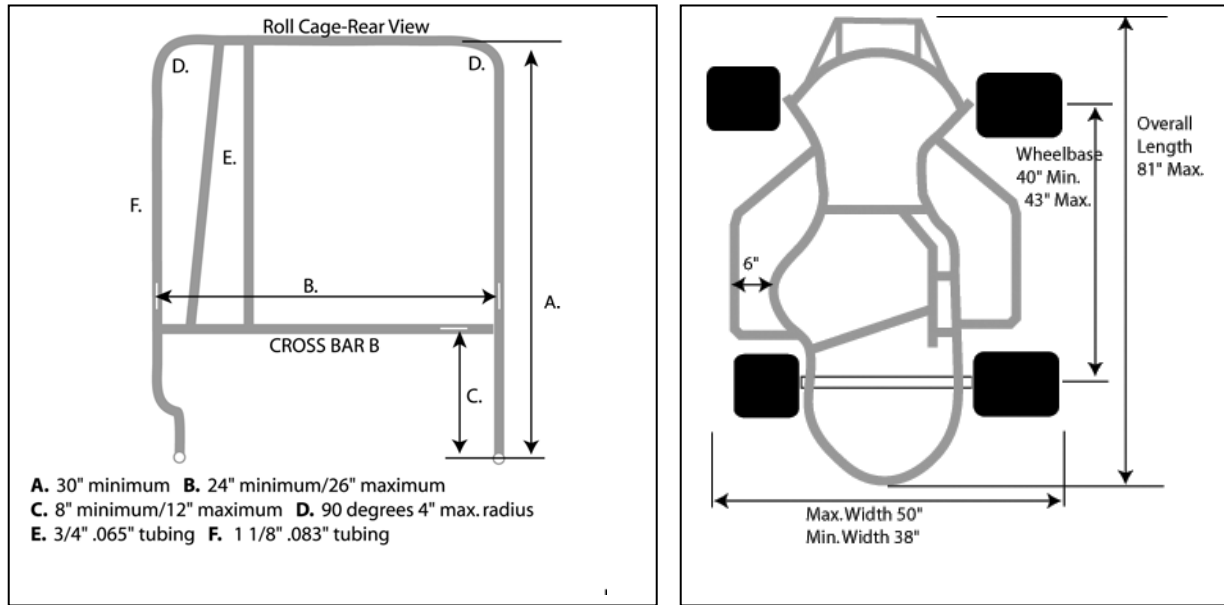

4.9 Roll cage specific specifications

- 4.9.1 Full roll cage of four point conventional construction is mandatory. The four uprights and top horizontal connecting tubes must be constructed of 1.125-inch nominal minimum diameter mild steel tubing. All attachments by welding unless otherwise specified.
- 4.9.2 Uprights and positioning: Each of the rear uprights must be welded to the main frame rails at a point aft of the rear axle centerline. Each of the front uprights must be welded to the side frame rails at a point forward of the steering wheel mount point and aft of the leading edge of the front tire. All uprights must create an angle of no less than 45 degrees with the main frame rails and have no bends within three inches of attachment point except for left rear.
- 4.9.3 Top hoop rails: Corner construction shall be of rounded type with no sharp edges or corners allowed.
- 4.9.4 Shoulder harness mounting bar shall be welded laterally between rear uprights, double braced to the top lateral bar, at a height suitable for harness mounting. A minimum 6.0-inch square headrest shall be mounted to the braces level with the driver's head.
- 4.9.5 Side protection bars are mandatory and must run horizontally between front and rear uprights each side. One end connection may be slip jointed. Side protection bars must be positioned vertically between the driver's shoulder and elbow.
- 4.9.6 Roll cage side bar C overall width: 16.0 inches minimum 20.0" maximum. Width to be measured outside to outside between any two uprights.
- 4.9.7 Roll cage overall height: 30.0 inches minimum. Height to be measured vertically from highest lateral cross bar centerline to main frame rail centerline.
- 4.9.8 Front bumper: All components shall be constructed of round, .065 wall steel tubing of .750 inch nominal diameter minimum. Front bumper must encircle entire front nose area at a height of 7.75 inches minimum from ground level. Double bumpers are recommended.
- 4.9.9 Rear bumper: All components shall be constructed of round, .065 wall steel tubing of .750 inch nominal diameter minimum. Double bar construction is mandatory.

Rear bumper must encircle the tail section of the kart. The top of at least one bar must be 7.50 inches maximum from ground level.

- 4.9.10 Nerf bars: All components shall be constructed of round, .065 wall steel tubing of .750 inch nominal diameter minimum. Double bar construction is mandatory. The top of the upper bar must be no higher than the top of the rear tire. The bottom of the lower bar must be no lower than the bottom of the main frame rails. Nerf bar must extend from an area inside a longitudinal line from the outer portion of the front tire to a point no further outboard than 1.0 inch from outer tire surfaces.
- 4.9.11 Seat positioning: No part of the seat may be positioned closer than six inches inside the left-hand nerf bar.
- 4.9.12 Harness: five points, SFI-rated racing harness is mandatory. Metal to metal harness fastener is mandatory. Mounting bolts must be cotter-keyed and attach to a 3/16 inch minimum thick, 2.0 inch minimum square steel mounting plate that is welded to the frame and/or roll cage. Arm restraints, attached to the harness, are mandatory.
- 4.10 Junior Champ Kart Bodywork Requirements
 - 4.10.1 All bodywork components must be constructed of high strength plastic, fiberglass or advanced composites only.
 - 4.10.2 No component of the bodywork may be adjustable in any way while kart is in motion.
 - 4.10.3 Bodywork must be confined to the area defined by the front and rear bumpers, inside the area defined by the inside sidewalls of the tires.
 - 4.10.4 Cockpit must be entirely open when viewed from above.
 - 4.10.5 Wings, spoilers or other aerodynamic effects are prohibited. Including wind deflectors attached to the roll cage
 - 4.10.6 Full, midget/sprint type, open wheel, conventional construction methods only is approved. Flat panels are allowed only for side panels and all other body components must have rounded, compound curve configuration. Nose bodywork is mandatory.
 - 4.10.7 Full enclosing Midget/Sprint type tail section recommended. 15.0 inches minimum length, 13.0 inches minimum width and 14.0 inches minimum height.

Sprint Chassis Specifications

- 4.50 Tires
 - 4.50.1 Burriss 10X4.5-5, 11X6.0-5 or 11X7.10-5 in B44A or B55A compound only.
- 4.51 Wheels to be 5" bead diameter only with a maximum O/A width of 8.5". Material to be aluminum or magnesium only.
- 4.52 CIK style body work only on sprint (road course) chassis. No oval track (full) body work allowed.
- 4.53 All sprint (straight up) chassis to be of contemporary design. Rear axle diameter, 50 mm max. Aluminum or steel only.
- 4.54 More specifications coming in 2008.

SECTION 5 - POINTS AND AWARDS

5.1 Awards are presented to the top drivers who pass tech in each competitive class.

- 5.1.1 To receive points you must leave the grid under power, take the green flag, weigh in and pass post tech. Kart must qualify or participate to the extent the other competitors do. No “buying” points by just signing up.
- 5.1.2 Relief driver rules. You may use a relief driver for the Feature Event if the registered driver qualified the kart or ran the heat race. The relief driver must notify the Race Director of the change and start at the back of the field.
- 5.1.3 The driver is the official entry into the event. You may change karts or engines with the approval of the Technical Director. All equipment used in qualifying and or heat race is subject to post race inspection. If any part fails post race inspection the drivers is disqualified for the event.
- 5.1.4 Disqualification: In the event a driver is disqualified from that event for unsportsmanlike conduct on or off the racetrack, he may NOT use that as a drop race in series that use drop races.
- 5.1.5 If a driver is disqualified for improper driving, post-race engine infractions, oil or fuel tech or at the scales in post tech, he may NOT use that as a drop race in series that use drop races.
- 5.1.6 If a driver is disqualified for mechanical failure on the track, he may use that as a drop race in series at use drop races. However, if repeatedly disqualified for any reason the driver may be subject to penalty of not being able to use a race as a drop race.

5.2 Scoring method

5.2.1 The following point method will be used for calculating season points in all divisions

Finish	Points	Finish	Points	Finish	Points	Finish	Points	Finish	Points
1st	180	7th	146	13th	124	19th	106	25th	88
2nd	170	8th	142	14th	121	20th	103	26th	85
3rd	165	9th	138	15th	118	21st	100	27th	82
4th	160	10th	134	16th	115	22nd	97	28th	79
5th	155	11th	130	17th	112	23rd	94	29th	76
6th	150	12th	127	18th	109	24th	91	30th	73
									Positions 31 and lower receive 70 participation points.

- 5.2.2 In the event of a rainout all entrants will receive 175 pts.
- 5.2.3 In the event of a tie in year end points total, the tie will be broken by the most number of wins for the season, Second tie breaker is most number of second, then thirds, then fourths.

SECTION 6 - PROTEST PROCEDURE

- 6.1 All protests must be submitted in writing to the Race Director within 30 minutes of completion of the race that is being protested or, in the case of a scoring protest, within 30 minutes after official results have been posted and the results are declared official by the Race Director. A protest can only be submitted by an entrant from the same class that is being protested, and can only be signed by one entrant. Once the official has accepted a protest, additional protests for the same infraction will not be accepted. The Race Director will decide all protests before parties involved leave the track.
- 6.2 Protests for technical disqualifications must be submitted in writing within 30 minutes of the announced infraction by the tech inspectors. These infractions are to be resolved (upheld or reversed) by the Race Director and his tech officials prior the ending of the event for the day.

SECTION 7 - CLASS STRUCTURE

- 7.1 F200 OHV Speedway – Approved BNSS F200 engines per Section 9. “Pump” gas only. Tires per Section 4.1.
- 7.1.1 F200-OHV SR. Age 15 & up - 360 lbs. .790” venturi carb (rule 9.4). Weights for Lite and Heavy are 350 and 370 respectively.
 - 7.1.2 F200-OHV JR. III Age 12-15 years - 300 lbs. .790” venturi carb (rule 9.4) with 18mm (.709”) restrictor (rule 8.8). Weights for Lite and Heavy are 290 and 310 respectively.
 - 7.1.3 F200-OHV JR. II Age 10-12 years - 275 lbs. .790” venturi carb (rule 9.4) with 16mm (.630”) restrictor (rule 8.8). Weights for Lite and Heavy are 265 and 285 respectively.
 - 7.1.4 F200-OHV JR. I Age 8-10 years - 250 lbs. .790” venturi carb (rule 9.4) with 14mm (.551”) restrictor (rule 8.8). Weights for Lite and Heavy are 240 and 260 respectively.
- 7.2 F200 OHV Speedway Champ – Approved BNSS F200 engines per Section 9. Pump gas only. Tires per Section 4.1.
- 7.2.1 CHAMP F200-OHV SR. Age 15 & up - 400 lbs. .790” venturi carb (rule 9.4). Weights for Lite and Heavy are 390 and 410 respectively.
 - 7.2.2 CHAMP F200-OHV JR. III Age 12-15 years - 330 lbs. .790” venturi carb (rule 9.4) with 18mm (.709”) restrictor (rule 8.8). Weights for Lite and Heavy are 320 and 340 respectively.
 - 7.2.3 CHAMP F200-OHV JR. II Age 10-12 years - 315 lbs. .790” venturi carb (rule 9.4) with 16mm (.630”) restrictor (rule 8.8). Jr. Sportsman Champ chassis rules apply. Weights for Lite and Heavy are 305 and 325 respectively.
 - 7.2.4 CHAMP F200-OHV JR. I Age 8-10 years - 300 lbs. .790” venturi carb (rule 9.4) with 14mm (.551”) restrictor (rule 8.8). Sportsman Champ chassis rules apply. Weights for Lite and Heavy are 290 and 310 respectively.
- 7.3 BRIGGS 5 hp Tires per Section 4.1
- 7.3.1 4 CYCLE SR. Age 15 years & up - 360 lbs. - Methanol only -Approved engine: Briggs & Stratton stock 5hp. Weights for Lite and Heavy are 350 and 370 respectively.
 - 7.3.2 4 CYCLE JR. III Age 12 to 15 years - 300 lbs. - Methanol only - Approved engine: Briggs & Stratton stock 5hp with .575 inch intake restrictor. (rule 8.9) Weights for Lite and Heavy are 290 and 310 respectively.
 - 7.3.3 4 CYCLE JR. II Age 10 to 12 years - 275 lbs. - Methanol only - Approved engine: Briggs & Stratton stock 5hp with .500 inch intake restrictor. (rule 8.9) No steering fairing allowed, maximum nose height 14 inches from ground level to top of nose. Weights for Lite and Heavy are 265 and 285 respectively.
 - 7.3.4 4 CYCLE JR. I Age 8-10 years - 260 lbs. - Methanol only - Approved engine: Briggs & Stratton stock 5hp with .425 inch intake restrictor. (rule 8.9) No steering fairing allowed, maximum nose height 14 inches from ground level to top of nose. Weights for Lite and Heavy are 250 and 270 respectively.
- 7.4 OPEN Tire Rule. Any Burriss Tire
- 7.4.1 Unlimited – RWYB. Minimum weight is 350 lbs.
- 7.5 F200 OHV Sprint – Approved BNSS F200 engines per Section 9. “Pump” gas only. Tires per Section 4.5.
- 7.5.1 F200-OHV SR. Age 15 & up - 350 lbs. .790” venturi carb (rule 9.4). Weights for Lite and Heavy are 340 and 365 respectively.

- 7.5.2 F200-OHV JR. III Age 12-15 years - 300 lbs. .790" venturi carb (rule 9.4) with 18mm (.709") restrictor (rule 8.8). Weights for Lite and Heavy are 290 and 310 respectively.
 - 7.5.3 F200-OHV JR. II Age 10-12 years - 270 lbs. .790" venturi carb (rule 9.4) with 16mm (.630") restrictor (rule 8.8). Weights for Lite and Heavy are 260 and 280 respectively.
 - 7.5.4 F200-OHV JR. I Age 8-10 years - 245 lbs. .790" venturi carb (rule 9.4) with 14mm (.551") restrictor (rule 8.8). Weights for Lite and Heavy are 235 and 255 respectively.
 - 7.6 KT 100 Sprint Classes – Coming soon!
 - 7.7 Local Option and Kids Class Tire Rule. Any Burriss Tire.
 - 7.7.1 KID KARTS Age 5 to 8 years – Anything safe and slow. This is a training class and not intended for competition. Low horsepower 4 cycle engines recommended. A great opportunity to learn car control, proper reactions to the various flags and on track safety.
 - 7.7.2 LOCAL OPTION CLASSES May be included in local/regional series as needed. They are not eligible for awards and/or sponsorship without prior approval of the BNSS.
 - 7.8 Local promoting organizations should decide on their class make up from the BNSS National classes listed. Your organization is not expected to run all available classes.
- Note: Lite and Heavy weight classes are for multi day events or for larger programs that need to split the classes into more manageable sizes.

SECTION 8 - GENERAL ENGINE RULES AND TECHNICAL PROCEDURES

Governing Philosophy of the Burriss National Speedway Series Technical Regulations

The rules set forth are designed to be a guide for technical inspectors to insure fair competition within the Burriss National Speedway Series. While the BNSS encourages innovation and engineering within its technical guidelines, certain modifications deemed to be against the spirit and intent of rules set forth shall be declared illegal. It is the sole discretion of the technical inspector and race director to decide if any modification outside of the rules laid down here will be deemed illegal for competition. Any means of introducing air to the engine, except from the inlet of the carburetor is illegal. Any means of modifying the engine or exhaust system to introduce air or bleed of exhaust gasses is illegal.

- 8.1 Gasoline General Rules - All 2 and 4 cycle engine classes designated "Gasoline only" will use commercially available roadside "pump" gasoline with a maximum of 93 octane. For major events or where a spec fuel is desired the hosting track should specify where the source fuel is to be obtained. This can be fuel supplied at the track or a nearby service station. All 2 cycle classes to use Burriss Castor and/or Blend with 6 oz/gal being the nominal oil to fuel ratio.
 - 8.1.1 2 Cycle Gas Tech -The tech inspector will draw one gallon of fuel from the source of race spec fuel. The inspector will add 6 ounces of Burriss Castor to the fuel sample. The sample will be kept in a shaded, cool location, under the control of the tech inspector. A Digitron meter must be set to 000 using the controlled sample. BNSS recommends zeroing the meter with spec fuel as opposed to using the cyclohexane method due to the potential for error due to reagent contamination and other environmental factors. Use of a single oil brand allows greater accuracy in the test results.
 - 8.1.2 4 Cycle Gas Tech - The tech inspector will draw one gallon of fuel from the source of the race spec fuel. The sample will be kept in a shaded, cool location, under the control of the tech inspector. A Digitron meter must be set to 000 using the controlled sample. BNSS recommends zeroing the meter with spec fuel as opposed to using the cyclohexane method due to the potential for error due to reagent contamination and other environmental factors.
 - 8.1.3 Competitors are allowed plus or minus 10 on the meter and are eligible for one re-check following a failed test.
- 8.2 Methanol Test General Rules-100% methanol with no additives or oil is the only fuel allowed in Methanol specified classes.
 - 8.2.1 For major events or where a spec fuel is desired the hosting track should specify where the source fuel is to be obtained. This can be fuel supplied at the track by the promoter or an approved vendor. Comparison testing can be done with a hydrometer or by the water test described below.
 - 8.2.2 Methanol water test. Using a clean glass bottle, fill with less than half of the bottle's volume with methanol. Fill with the same amount of distilled water. Mix thoroughly and let set for five minutes. If the test sample shows cloudiness, milkiness or contains precipitates, the participant's fuel is illegal.
 - 8.2.3 A pump-around fuel distribution system is a satisfactory replacement for a hydrometer test or the water test.
- 8.3 4 Cycle Exhaust Systems: The exhaust system must be of a fixed design and cannot be adjusted while the kart is in motion. (i.e. no slippy pipes) Length is non tech. System may consist of one to three pieces (header, connector tube and tail pipe) plus a silencer (if required). These components to be stainless or low carbon steel materials only. Exhaust pipe/header may not extend past rear bumper (including silencer, where

applicable) Studs allowed to attach the header to cylinder head. Sealer and gaskets non-tech. If a silencer is required, the RLV Model B91/B-91XL (Pt# 4104) is the only approved model and must be ran stock with no modifications allowed regardless if they were by damage or intentional.

- 8.4 2 Cycle Exhaust Systems: The exhaust system must be of a fixed design and cannot be adjusted while the kart is in motion. (i.e. no slippy pipes). The pipe must fit the factory dimensions and specifications. No modifications permitted. EGT probes and fittings are non-tech. Safety wire to secure the end piece of the system is non-tech. A loose exhaust can on a kart during a competitive event is cause for a black flag.

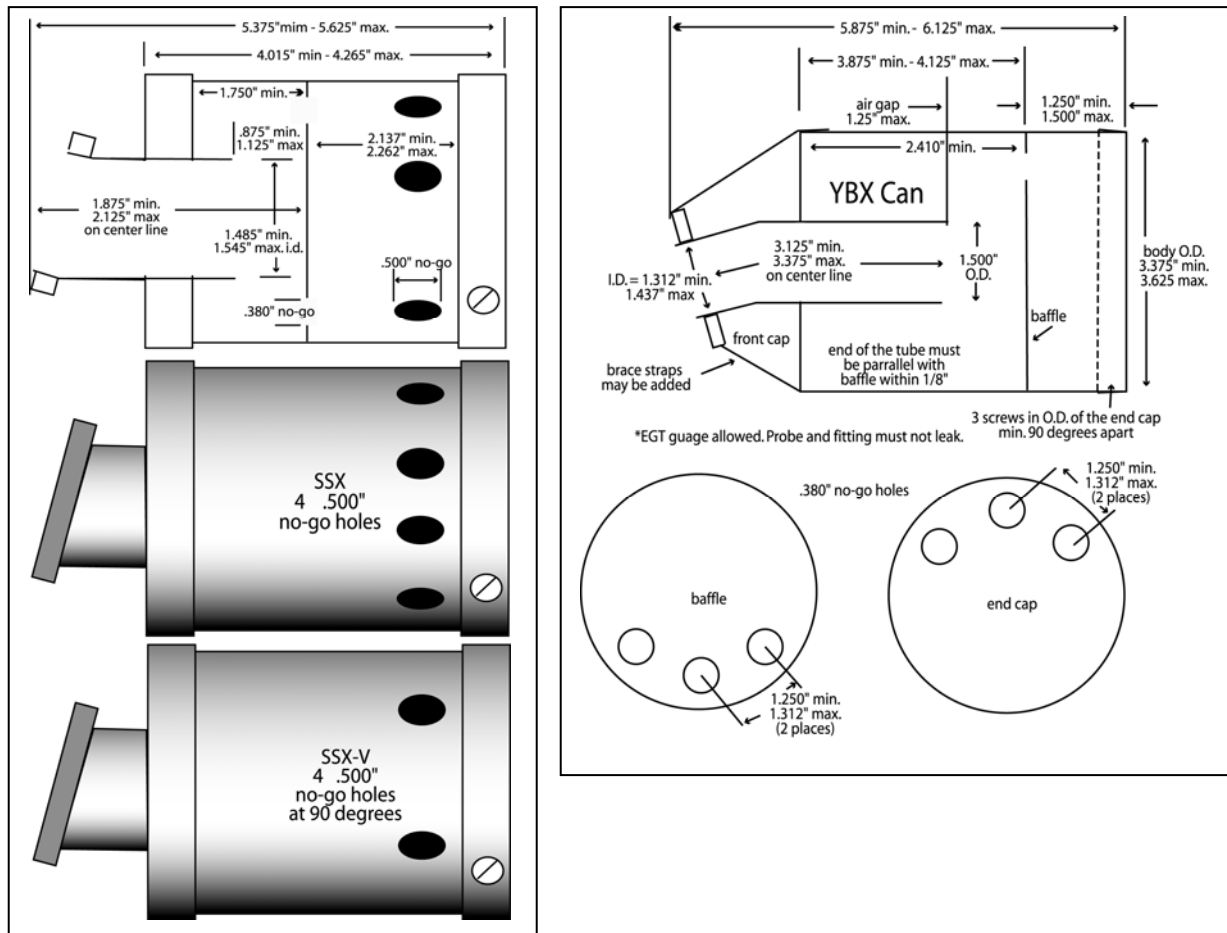

- 8.5 Combustion Chamber Volume Testing Procedure - Extreme care must be used to obtain accurate and reliable results.

- 8.5.1 Fill a 25cc (.1cc calibration) burette with Marvel Mystery Oil. Care must be taken to allow trapped air bubbles to escape. Flush the air from the stopcock and outlet.
- 8.5.2 Install the combustion chamber measuring plug and torque to 90 in. lbs. Roll the piston to approximately .100 before top dead center.
- 8.5.3 Fill the combustion chamber with the designated amount (24cc for F200, 11cc for KT100) of Marvel Mystery Oil from the burette.
- 8.5.4 Roll the piston up through top dead center. If any oil escapes the top of the combustion chamber plug, the engine is illegal.

*Special note – It may be necessary to remove the engine from the kart so the “Combustion Chamber CC Tool” hole is in a vertical position. Also note if the camshaft has a compression release the exhaust rocker arm must be loosened to disable this feature.

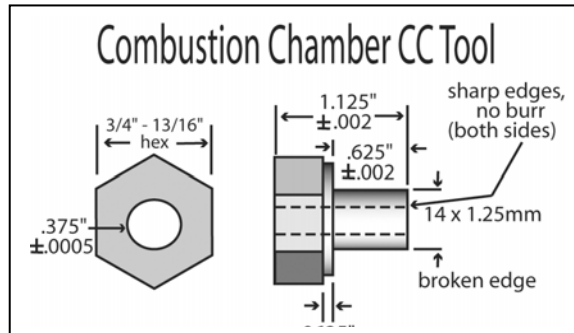

8.6 Centrifugal clutches only in all classes. (No direct drive.) 219 or 35 chain only. No belt drives

8.7 Recommended Tech procedures for F200's.

8.7.1 “Level 1” tech would be a camshaft lift check, a combustion chamber cc check, and a carburetor venturi/throttle bore (and restrictor plate if required) check as well as an external engine check. This can be used at the club level and most weekly races.

8.7.2 “Level II” check would require the removal of the cylinder head to check bore and stroke and valve diameters and other related components in that area. This is a more involved procedure and can be used randomly as a deterrent or when infractions in that area are suspected.

8.7.3 “Level III” tech would require removing the side cover to check the crankshaft, bearings, connecting rod and other components to confirm they conform to the rules and are of the proper material. This can be used as an extension or a more comprehensive tech to a Level II for the above reasons.

8.8 F200 Junior Restrictor Plate. Must be as supplied by the BNSS and no alterations are permitted. It is to be mounted between the intake manifold and carburetor. No Go diameter of the main restrictor hole and the .090” diameter equalizer/drain holes are +.001” from the dimension in parenthesis.

- Junior I = 14mm (.551”) dia.
- Junior II = 16mm (.630”) dia.
- Junior III = 18mm (.709”) dia.

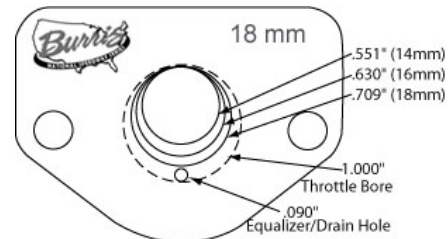

Note: F200 tech gages are available at www.rixkartengines.com or 330-494-5107.

8.9 Briggs 5 hp Jr. Restrictor Plates. Flat style only with sharp edge. No beveled or swaged holes. Maximum hole diameter is as follows; Purple = .425”, Turquoise = .500” and Gold = .575”.

SECTION 9 - F200 TECHNICAL SPECIFICATIONS



- 9.1 Approved, commercially available, single cylinder air-cooled overhead valve engines. 200 cc's maximum displacement. See Chart for approved engines.
- 9.2 Block, Cylinder Head, Crankshaft and Side Cover: Must be approved OEM items. Cylinder head, block and side cover external surfaces may be machined to remove excess material from mounting bosses, cast in brackets, etc that are no longer in use. No external machining allowed to enhance performance.
- 9.3 Exhaust System: See rule 8.3
- 9.4 Carburetor: Any commercially available butterfly type Tillotson HL series carb. Minimum/maximum venturi diameter = .750/.790". Minimum/maximum throttle bore diameter = .990/1.010". Metering holes non-tech. Restrictor plates are suggested in all Junior classes. See Section 8.8 for recommendations. Filter cups, adapters and air filters non-tech items. The carburetor pulse passage is non tech but can not be used to bypass the restrictor plate. Its sole and intended purpose it to actuate the fuel pump inside the carburetor. Pulse type fuel pumps permitted.
- 9.5 Fuel: See rule 8.1 and 8.1.2
- 9.6 Intake manifold: Aluminum only with a minimum runner/passage diameter through manifold to be .75". Maximum mean inlet tract length is 2". Length determined by adding the longest and shortest tract distances (flange to flange) together and dividing by 2.
- 9.7 Connecting Rods: Aluminum or steel only. (Fasteners and inserts/bushings excluded) Stock length (plus or minus .010") to be maintained. See chart for specific details.
- 9.8 Pistons: Any aluminum three ring (compression, scraper and oil and they must be present in grooves), flat top or dished piston. (No domed or pop up types) Rings and wrist pin non-tech but must be of steel (ferrous) material. OEM wrist pin diameter to be maintained. See chart for maximum bore size and wrist pin diameter for a specific engine.
- 9.9 Crankshaft: Standard OEM item with stock stroke length (plus or minus .010"). Thermal treating and shot peening permitted. Minor grinding for camshaft clearance and welding cam gear to crank permitted. No other alterations allowed. See list for specific stroke details.
- 9.10 Flywheel and Ignition Coil: Aftermarket or OEM flywheels permitted. If OEM flywheel is used it must be unaltered and meet minimum listed weight the stock OEM coil (ignition system) must be used. Approved aftermarket flywheels only may be used. Spec diameter and weight as follows; 6.75" +/- .25" dia. X 4.75 lbs +/- .75 lbs. When using aftermarket flywheels, any approved OEM F200 coil may be used on any engine. (i.e. Briggs coil on a Honda, Tecumseh coil on a Kohler, etc) External coil modifications to facilitate mounting are legal. Coil mounts, flywheel key, spark plug boots and plug wires are non tech items. See below for approved flywheels.
- 9.11 Cylinder Head: Original factory casting only. Two valves maximum and must maintain original location, (angles are 90° from deck with listed spacing). Carb inlet and exhaust outlet in the head have to be in their stock intended locations. Porting and grinding permitted. No external addition of metal to enhance performance allowed. Spark plug to be 14mm X .75 reach only and original stock location maintained. Minimum combustion chamber volume when mounted on engine @ TDC is 24 cc's using

- prescribed procedure as noted in rule 8.5. This is to be done after the event and when the engine has cooled down to a reasonable temperature. (Note – Briggs W/F head is legal but must use a 14mm spark plug)
- 9.11.1 Cylinder head repair. Aside from the above, each engine brand will be allowed an approved area on the inlet and exhaust tracts for external repair of broken through “thin cross sections” during the porting process if deemed necessary. The area shall be no greater than a .63” (16 mm) square and either epoxy or welding is acceptable. This repair has to be confined to the “approved” area shown on the list below.
- 9.12 Valve Train: Push rods, push rod guide plates, retainers, springs, keepers, rocker adjusters, etc, non tech. Steel valves, springs and push rods only. Retainers may be of aluminum or steel. Intake valve diameter, 1.080" maximum, exhaust valve, .990" maximum with a minimum stem diameter of .188" (4.77mm). Stock approved OEM rocker arms only (with no alterations to their stock ratio). No interchange of rocker arms between engine brands. Stock (Briggs) OEM cylinder head plates only. Rocker arms and (Briggs) cylinder head plates may be welded or reinforced for strength. No other alterations to original configuration permitted. Flat tappets only, must be stock appearing. Unless otherwise specified no titanium components allowed.
- 9.13 Camshaft: Maximum (actual running) lift .275" measured at valve retainer. This is to be done after the event and when the engine has cooled down to a reasonable temperature. Note – If the camshaft has a compression release it needs to be taken into account when zeroing the indicator on the exhaust lobe. Cam and crank gear non-tech.
- 9.14 Fasteners: Non-tech, but must remain in original location. Heli-coils, studs, etc allowed.
- 9.15 Gaskets: Non-tech.
- 9.16 Lubrication system: Must retain splash type oiling system.
- 9.17 Bearings: All ball and roller bearings shall be of metallic (magnetic steel) construction (excluding retainers) and be of conventional design. This includes inner and outer races as well as the balls and rollers. No other materials allowed.
- 9.18 Coatings: Wear type coatings allowed on valve train, valves, camshaft, wrist pin, rod and crankshaft only. Coatings of any type not allowed on block, head, piston, or side cover.
- 9.19 Crankcase breathers are to be routed internally through the valve cover as originally intended in OEM configuration. No additional breathers allowed.
- 9.20 Approved flywheels are the ARC models 6606, 6608, 6613 (w/starter ring gear), 6614 and the UMMF model FA-100 and the FS-1001. Briggs Animal flywheel (JR Racecar type pt #699305) (Note - the Briggs PVL ignition, it is not allowed at this time.)
- 9.21 Tires: See Section 4.1 for Oval specifications and 4.50 for Sprint
- 9.22 New engines are to be submitted by the manufacturer (or its authorized representative) for approval no later than October 1st to be eligible for the following competition year. OEM components (blocks, heads, cranks, side covers, etc) may be submitted quarterly (Jan, April, July, Oct) by the manufacture (or its authorized representative) at any time and must be available to the public for not less than 90 days after their approval before being legal for competition. Note - Approval is not automatic and is up to the discretion of the BNSS.

Approved Engines and Specifications

Make	Briggs	Honda	Kohler	Tecumseh	Yamaha	Notes
Model	Intek 5.5*	GX200	C6 XKE	OHV 5.5	YF200 R1	
Bore, Std	2.688	2.679	2.638	2.797	2.598	Standard Bore
Bore, Max.	2.760	2.709	2.783	2.833	2.809	Maximum allowed
Increase	0.072	0.030	0.145	0.036	0.211	Increase from std.
Stroke	2.040	2.125	2.008	1.938	1.968	Standard Stroke +/- .010
Rod length	3.375	3.303	3.425	3.484	3.324	Cntr to Cntr. Tolerance is +/- .010
Rod length	2.514	2.358	2.540	2.703	2.459	Inside length
Wrist pin dia	0.625	0.708	0.550	0.563	0.630	Tolerance is +/- .0025
Rod journal	1.098	1.180	1.218	0.999	1.101	Tolerance is +/- .0025
Flywheel	5.75 lbs	5.75 lbs	8.1 lbs	7.0 lbs	6.5 lbs	Approx. weight in pounds
Valve spacing	1.382	1.219	1.380	1.250	1.181	Valve angles are 90° from deck
* Briggs Animal & World Formula blocks, heads and side covers also approved.						

Approved Port Repair Areas. See 9.11.1 for details.



Approved Yamaha YF200 Inlet Tract Repair Area

F200 and BNSS are registered trademarks of Burriss Racing. Any use or advertising of these rules or the BNSS and F200 trademarks with out the consent of Burriss Racing is strictly forbidden. To guarantee the integrity and global continuity of the BNSS and F200, any alteration to these rules or programs while running under the guise of F200 or BNSS formats is strictly forbidden.

SECTION 10 - BRIGGS AND STRATTON 5HP TECHNICAL SPECIFICATIONS

Note – Due to the announcement by Briggs and Stratton that this engine and certain components are being phased out of production soon; the BNSS will be looking at suitable aftermarket replacement parts to approve on an ongoing basis. This will insure that those BNSS participants using the 5 hp flat head engine will not have to experience shortages and/or escalating costs.

General: All components to be OEM Briggs & Stratton unless otherwise specified. Gaskets and fasteners non-tech unless otherwise specified. Gasket sealer on all machined surfaces acceptable.

- 10.1 Cylinder head requirements: Machining permitted on the gasket mating surfaces and the top of the post bosses only. Welding on the cylinder head is prohibited. Heli-coil repair of spark plug threads in original position permitted, no protrusion into combustion chamber allowed. Bolt hole diameters .348" maximum. Combustion chamber depths: piston area .011" minimum, spark plug area .408" minimum, valve area .300" minimum. Head gasket material non-tech but must be stock configuration and .043" minimum thickness. Eight stock head bolts required.
- 10.2 Bore and Stroke: 2.6025" maximum bore, 2.437 +/- .010" stroke. Protrusion of the piston above the top of the cylinder deck is .005" maximum parallel and inline with the wrist pin. *(See foot note)
- 10.3 Carburetor requirements: Stock Briggs & Stratton 5hp carburetor only. Filter adapter (if utilized) top surface must be flat and .250" maximum thickness from mounting face. Inside diameter of adapter may be radiused .250" maximum. No more than one filter adapter gasket may be used, thickness .075" maximum. One or two carburetor mounting flange gaskets may be used. Swirl non-tech. Throttle shaft washer and rubber seal must be in place and stock configuration. Throttle shaft leading edge .040" minimum, trailing edge .086" maximum. Butterfly must be unaltered stock with .059" minimum thickness at throttle shaft mating location. Butterfly screw must be unaltered stock, .322" minimum length. Except for outside end, needle screw must be unaltered stock with o-ring and washer present. Jet must have stock recess on backside with no funneling of hole allowed. Main metering hole diameter .062" maximum. Idle hole diameter .028" maximum. Air horn diameter 1.011" maximum. Recess at flange end must be as cast, .726" maximum diameter. Carburetor bore, from flange end recess to intersection of air horn diameter, .695" maximum diameter – must be straight, no tapering, no attempts to modify fuel/air flow permitted (rifling, dimpling, protrusions etc. not permitted). Diaphragm cover plate may be faced for proper sealing. Aftermarket diaphragm of stock configuration permitted. Spring and cup must be unaltered stock. Long fuel pickup tube may not be brass. Short tube inside diameter .066" maximum. Breather tube must be removed. Any stock, single hole, domed Briggs & Stratton fuel tank cap is permitted including those with integral splash shields.
- 10.4 Exhaust: See rule 8.3
- 10.5 Valve train: Stock, unaltered breather valve only. Two gaskets permitted. Grommet and internal foam must be in place. Stock, unaltered, single angle valves only. Length of flat from seating surface to end of valve .035" minimum. Intake valve angle 30° +/- 1°, 1.115" minimum head diameter. Exhaust valve 45° +/- 1°, .990" minimum head diameter. Stock valve springs and lower retainers required. Springs may be machined to meet length requirements. Exhaust spring must be used on exhaust valve and may be used on intake valve. One stock upper retainer may be used on either valve, .058" maximum lip thickness. Intake valve spring length 1.240" maximum; .087" maximum wire diameter. Exhaust valve spring length 1.300 " minimum, 1.500 " maximum, .088 " minimum wire diameter; inside spring diameter .625 " minimum, .640 " maximum. Both

upper valve chamber surfaces may be spot faced for valve spring stabilization. Depth and geometry of spot face non-tech. Stock, single angle valve seats required. Valve seat height to cam centerline 5.740" minimum, 5.775" maximum. Valve seat may not protrude above cylinder deck surface.

- 10.6 Ignition systems: Stock, unaltered coil and coil air vane required. OEM plug wire only. Connector and plug boot non-tech. Resistance from spark plug wire to ground is 2,000 ohms minimum, 5,000 ohms maximum. Stock, unaltered 5hp flywheel required. Flywheel weight, 5 lbs 12 oz's minimum. (*Due to the pending shortage of 6 lb 4 oz flywheels the BNSS has reverted to the old weight to allow the use of the many lighter flywheels that are in the system but are not currently legal with other sanctioning bodies.*) Flywheel coating of any type is prohibited. Revolving or adjustable flywheel screens are prohibited. Flywheel key is optional and non-tech.
- 10.7 Piston requirements: Approved commercially available aluminum piston and ring configuration permitted. (Briggs, Burriss, Wiseco approved Super Stock type.) Length from top of piston to top of wrist pin bore .925" minimum. (Decking of piston permitted to adjust pop up within the .925" min.) Wrist pin outside Diameter .490 " maximum, inside diameter .290 " maximum, length 1.727 " minimum, 1.737 " maximum.
- 10.8 Rings: All three required. Must be stock appearing.
- 10.9 Connecting rod requirements: Approved commercially available aluminum connecting rod is permitted. Length from bottom of wrist pin bore to top of crankshaft journal bore 3.1233 " minimum, 3.1333 " maximum. Connecting rod bolts and dipper are non-tech.
- 10.10 Crankshaft requirements: Stock crankshaft required. Machining, polishing, addition of material or otherwise altering of counterweights is prohibited. Stock timing gear in stock configuration required. Connecting rod journal diameter .990" minimum, Crankshaft journals may be clearance to .775" minimum diameter to facilitate bearing removal. Thermal treatment of crankshaft is permitted.
- 10.11 Camshaft requirements: Camshaft base circle is .770 "diameter maximum. Lifter material to be ferrous steel only. Lifter head diameter .982"minimum, 1.005" maximum, Length 1.606" maximum. Cam profile check must be taken with zero (0) valve lash.

Camshaft profile limits

Lift	Exhaust degrees	Intake degrees
.050	38°BBDC to 33°BBDC	7°BTDC to 0°TDC
.100	21°BBDC to 16°BBDC	10°ATDC to 17°ATDC
.150	2°BBDC to 3°ABDC	29°ATDC to 36°ATDC
.200	21°ABDC to 31°ABDC	55°ATDC to 64°ATDC
Max	.233 " maximum	.233 " maximum
.200	76°BTDC to 65°BTDC	43°BBDC to 33°BBDC
.150	48°BTDC to 40°BTDC	13°BBDC to 6°BBDC
.100	28°BTDC to 21°BTDC	6°ABDC to 13°ABDC
.050	10°BTDC to 4°BTDC	23°ABDC to 31°ABDC

- EZ Spin: start 45° to 60° ABDC
 - EZ Spin lift base: .013" minimum, .019" maximum, 30° minimum duration, .001" maximum drop during duration.
- 10.12 Block requirements: Side cover must be stock. Stub for governor may be removed and hole plugged. Gasket mounting surface of side cover and block may be pin punched. Block must be unaltered stock with the following exceptions. The lifter bores may be countersunk to provide lifter head fillet radius clearance. Any means to raise the bottom

of the lifter bore boss is prohibited. Welding to the block shall be for damage repair or lifter bore reinforcement only and may not constitute a functional modification. The cylinder deck may be machined, but cannot extend into the rear fin. Carburetor and exhaust pipe mounting surfaces must be unaltered stock. Alterations to inside surfaces of intake and exhaust ports are allowed so long as the intake port will not accept an .880 " diameter No-Go plug gage and the exhaust port will not accept a 1.005 " diameter No-Go plug gage. No addition of material is allowed. No additional holes may exist in the intake and/or exhaust ports. No alterations on the underside of the valve seats are allowed. Cylinder sleeve, if present, shall be ferrous material and uncoated.

*(Note: Areas wishing to allow IKF legal engines (w/ .015" popup) may do so as a local option. Participant must declare which rules the engine conforms to prior to teardown.)

SECTION 11 - YAMAHA KT100 TECHNICAL SPECIFICATIONS

- 11.1 Description: Yamaha KT100S 2 cycle, single cylinder, piston port.
- 11.2 Displacement: 6.201 cubic inches/101.6 cubic centimeters maximum.
- 11.3 Bore and Stroke: 2.085" maximum bore, 1.816" maximum stroke.
- 11.4 Gaskets and Fasteners: Non-tech unless otherwise specified.
- 11.5 Exhaust Systems: See rule 8.4
- 11.6 Combustion Chamber Volume: 11.00 cubic centimeters minimum. Measured using standard accepted karting test methods. See rule 8.5
- 11.7 Cylinder Head Requirements: The combustion chamber must be spherical in shape with a visible squish band. Cylinder head gasket shall be manufactured of aluminum or copper only, having a 2.580" maximum outside diameter.
- 11.8 Port Dimensions and Specs: Note: grinding of all port surfaces to dimensions shown in diagram allowed. Surface finish of all ports is non-tech. Use LAD port checking tools.
- 11.9 Inlet Tract Length: 2.600" minimum, 2.800" maximum
- 11.10 Intake Port Opening Dimension: .775" ATDC max.
- 11.11 Exhaust Port Opening Dimension: 1.155" ATDC min.

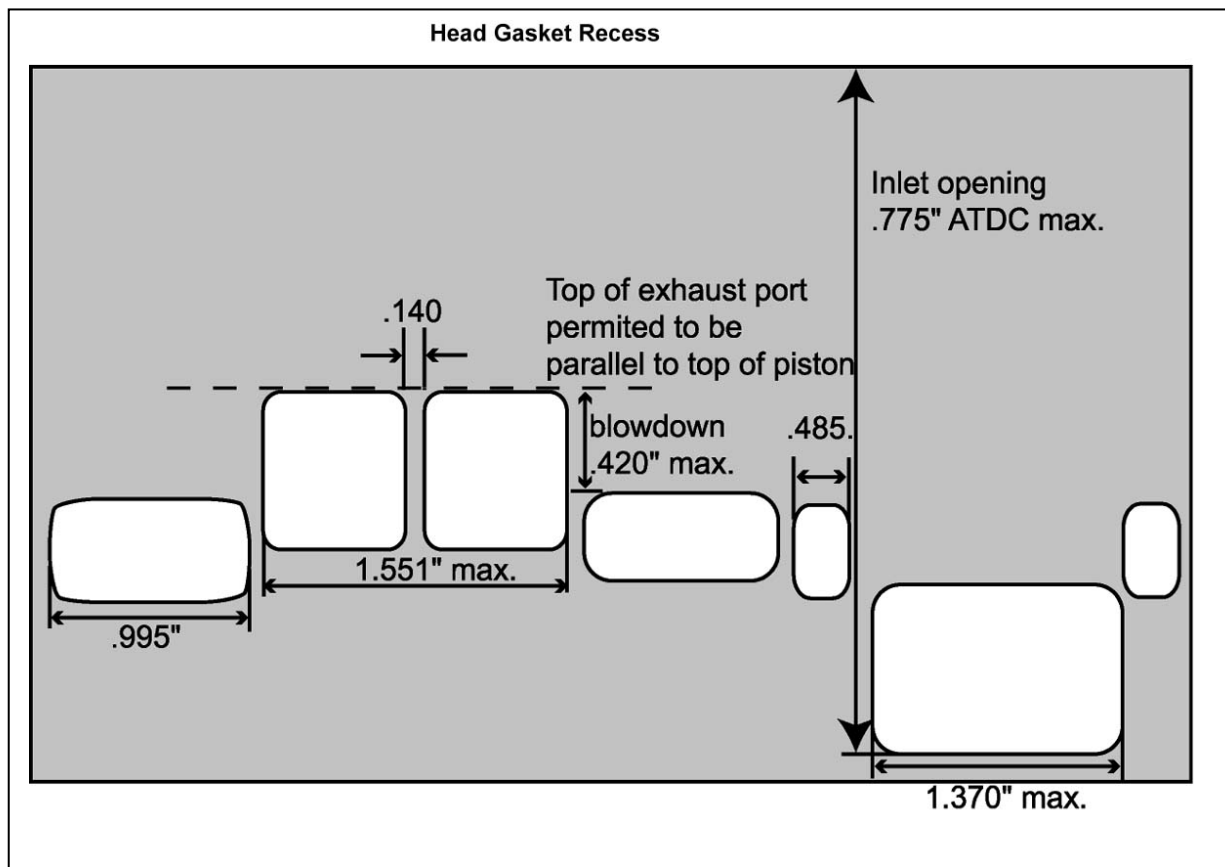

- 11.12 Ignition System: Only spark plugs manufactured with a .750" nominal reach are allowed. Approved flywheels are Yamaha part numbers 7F6-85551-00, 7F6-85551-50 (Old style), 7F6-85551-01, 7F6-85551-51 and 7F6-85510-03-00 (New style). Flywheel outside diameter 2.350" minimum. New style flywheel thickness over (3) lugs .950" minimum, all other areas .817" minimum. New style lug length, (3) places .750" minimum. Old

style flywheel thickness .827" minimum. Flywheel and crankshaft keyway width and key is non tech. Ignition module must be original Yamaha, PRD or Atom, stock appearing, unaltered, silicone or epoxy damage repair is allowed. Coil may be repaired with silicone or epoxy.

- 11.13 Piston and Wrist Pin Requirements: Approved pistons are Yamaha, Burriss (single or double ring), Wiseco, Vinart and KSI RKE-787. All approved pistons have manufacturer's name cast inside and this must be present. Piston coatings allowed. Piston skirt length must be the same within .015" front to back. Maximum .030" piston skirt corner break, measured axially. Circlip circumferential height .250" maximum, axial width .200" maximum. Piston transfer areas must be as cast. Piston must be domed. All pistons (except Burriss double ring) must have one ring only. Rings must be manufactured of ferrous material. Wrist pin length 1.565" minimum. Wrist pin outside diameter .550" minimum, .552" maximum. Wrist pin inside diameter .400" maximum. Wrist pins to be manufactured of ferrous material.
- 11.14 Connecting Rod Requirements: Approved connecting rods are Yamaha part numbers 7F6-11651-01, 7F6-11651-02 and 50W-11651-00 only. The connecting rod must be of original manufacture and stock appearing with no machining, grinding, blending or polishing allowed. Shot peening the connecting rod is allowed. Center of crankshaft journal diameter to center of wrist pin diameter 3.932" minimum, 3.942" maximum. Top or bottom-guided rods and bearings allowed.
- 11.15 Crankshaft Requirements: OEM only. Crankshaft outside diameters to be 3.410" minimum, 3.435" maximum. Width over bearing lands 1.790" minimum. Inside width between counterweights .343" minimum. Concentric bushings may be added to repair damaged crankshaft journals. Removal of material in bearing recess area is allowed for bearing clearancing only, not for lightening or balancing purposes. Crankpins are non-tech.
- 11.16 Carburetor Type: Walbro WB3A only. .950" maximum venturi diameter. (See diagram.) Must be stock appearing. Polishing of the venturi, air horn and throttle bore allowed. Metering holes non-tech. Filter cups and air filters non-tech. Pulse pipe and tube non-tech.

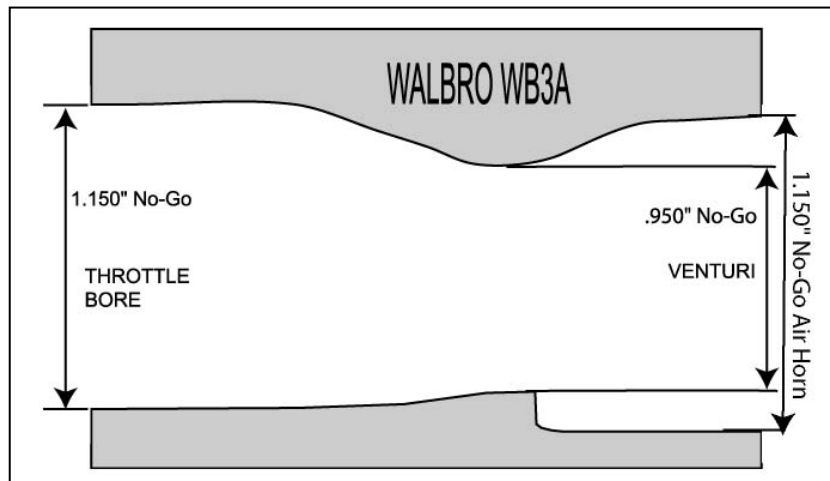

SECTION 12 - SECTION 12 - CLONE TECHNICAL SPECIFICATIONS

12.1 Rules & Intent: The intent of this engine package is to provide a low cost out of the box power source to attract new or budget minded karter's to local and regional level karting. That being said, it has to be acknowledged that there are certain convenience and/or safety modifications that have to be allowed as well as some dimensional guide lines to verify the engines legality should there be a need to inspect internal components. The following are recommended areas of inspection should it become necessary.

12.2 Approved engines - OHV engines generally referred to as Clones with a maximum displacement of 200 cc's. (Current legal engines include the Lifan, Grey Hound, Harbor Freight Blue & Yellow, Jaing Dong, Yamakoyo, Blue Max)

12.3 Engine Components: Must be original OEM items in their stock state unless otherwise specified. Removal of unnecessary OEM items such as exhaust system, air cleaner, fuel tank, governor, low oil sensor, etc is permitted. Welding or epoxy repair permitted to the block, head and side cover provided they don't enhance performance.

12.4 Exhaust System: Non tech except header must be round and a constant diameter (no multi stage) and the end may be expanded to accommodate an RLV type B91 or other muffler/silencer. No loop type exhaust. Silencers are strongly recommended. If a silencer is not used the end of the pipe must be flared or have a protective washer welded on.

12.5 Carburetor: Huayi type carb only. Choke assembly must be in place and functional. Choke bore .810" dia max, venturi .615" max and throttle bore .751" max. Main metering jet is non-tech. (Since the amount of air flow is controlled as well as the fuel teching the jet size is unnecessary) Filter adapter and filter non tech. Any pulse type fuel pump permitted and can be pulsed from the crankcase, side cover or valve cover.

12.6 Fuel Tank: Non Tech. (It is recommended that for safety reasons remote/floor mounted tanks be used.)

12.7 Fuel: 93 Octane (max) Pump Gas. See rule 8.1 and 8.1.2 for details.

12.8 Clutch: Any engine mounted disk or shoe clutch allowed. (There are many used disc clutches available for a reasonable price) (Shoe/drum clutches only can be a local option)

12.9 Connecting Rods: OEM cast rods only. No modifications allowed.

12.10 Pistons: OEM Std bore (68mm or 2.677") only. Three ring design and all rings to be in tact and functional. (Oversize's to be permitted at a later date.)

12.11 Crankshaft: Standard OEM item with stock stroke length of 54mm or 2.126" (plus or minus .005"). No alterations permitted.

12.12 Flywheel and Ignition Coil: OEM stock/unaltered flywheels and plastic fins only. (no machining allowed) Flywheel key is non tech but must be installed. (Due to the variations of the OEM keys they will be non tech to allow optimum timing with a minimum of cost.) Plastic fins must be intact and have their full depth. Minimum (bare) flywheel weight is 5.0 lbs.

12.13 Cylinder Head: OEM heads only with no modifications allowed. Valve seats to be a single 45° only with a top angle relief of 30°. No porting, grinding or matching allowed to the ports or combustion chamber. Spark plug to be 14mm X .75 reach only. Minimum combustion chamber volume when mounted on engine @ TDC is 27.5 cc's using prescribed procedure as noted in rule 8.5. This is to be done after the event and when the engine has cooled down to a reasonable temperature. Head gasket to be .010" minimum thickness and can be either steel or aluminum.

12.14 Valve Train: OEM push rods, push rod guide plates, retainers, springs, keepers, rocker arms and adjusters only. OEM valves with 45° seat angle only and no lightening or polishing. Stock 1:1 ratio OEM rocker arms only. OEM valve springs only with a maximum spring diameter of .798" (wire diameter .073" max) and a maximum tension of 10.8 lbs at .850" compressed height.

12.15 Camshaft: Maximum (actual running) lift to be .245" measured at valve retainer. This is to be done after the event and when the engine has cooled down to a reasonable temperature.

No twisting or altering of the cam. Note - The camshaft has a compression release and it needs to be taken into account when zeroing the indicator on the exhaust lobe. The compression release must be intact and functional. Cam and crank gear cannot be altered or moved to change timing. (Note: Due to the changing specs from the various engines there may be some adjustments to the lift specs at some future date.)

12.16 Fasteners: Non tech, but must retain their original factory size. Heli coils, studs, etc allowed for repair purposes.

12.17 Gaskets & Sealer: Gaskets are non tech and sealer may be applied unless otherwise specified.

12.18 Bearings: Crankshaft bearings shall be of metallic (magnetic steel) construction (excluding retainers) and be of conventional design and the same dimensions as the OEM bearings. This includes inner and outer races as well as the balls and rollers. No other materials allowed.

12.19 Coatings: Internal performance coatings of any type not allowed.

12.20 Crankcase breathers are to be routed internally through the valve cover as originally intended in OEM configuration. No additional breathers allowed.

12.21 Tires: See Section 4.1 for Oval specifications and 4.50 for Sprint.

12.22 Claiming: Claiming is a Local Option and prices and conditions (such as what accessories are exempt from the claim, who gets to claim the engine in question, etc) are to be set by those entities.

12.23 Pull Starter: The pull starter is non tech and optional. It may be removed to allow the use of an auxiliary (hand held) starter or different brands of pull starters can be used on any the approved engines.